

# PRODUCT SPECIFICATION BULLETIN

## F SERIES

The Wizard® F Series is engineered for USDA-compliant drum cutting in food, pharmaceutical, and industrial settings, safely removing drum tops and bottoms for compact, liability-reducing disposal.



### ELECTRIC

*Electric Models are chosen when quiet operation is preferred.*

- 1/3 HP, 110-V, 60Hz, Single Phase, full load amps 5.7 and 220in/lbs torque
- Optional 220-V single phase/50 to 60Hz electric models available upon request
- Unit Dimensions: 29" x 29" x 13"
- Shipping Weight: 80 lbs.
- Completely enclosed, fan-cooled motor



### MANUAL AIR

*The air model is preferred in industrial settings where floors and work areas are wet.*

- 80-100 PSI, 25 CFM
- 1/2 HP, Variable Speed, 4-Vane Reversible Air Motor and 30:1 Gear Reducer
- Dimensions: 29" x 29" x 13"
- Shipping Weight: 80 lbs.

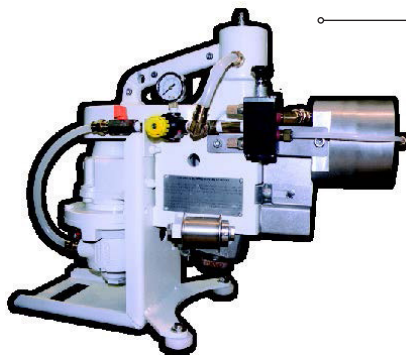

### AUTOMATIC AIR

*The automatic air model is effective when a large number of drums are being deheaded.*

- 1/3 HP, 110-V, 60Hz, Single Phase, Full load Amps 5.7 and 220in/lbs torque
- 1/2 HP, Variable Speed, 4-Vane Reversible Air Motor and 30:1 Gear Reducer
- Automatic powered cutting and Plunger Valve control
- Dimensions: 29" x 29" x 13"
- Shipping Weight: 84 lbs.
- Cutting pressure is automatically retained

## BENEFITS



- Fast - deheads in less than two minutes
- Removes entire drum head
- Does not come in contact with drum contents
- Low maintenance and long lasting
- Easy for flattening and drum recycling
- USDA compliant parts and approved cutting method for use