



Division of Hydro-Thermal Corporation PROVIDING SOLUTIONS WORLDWIDE

WIZARD DRUM TOOL CO.

Wizard®

**DRUM DEHEADER
OPERATING and SERVICE MANUAL**

Electric, Air and Automatic Air
Models F, G & J



Serial No. _____



Wizard Drum Opener Operating and Service Manual; Version 2.0, Rev D

TABLE OF CONTENTS

MODEL DESIGNATION AND FEATURES	1
GENERAL WARNINGS AND PRECAUTIONS	3
SECTION 1 - GENERAL INFORMATION	4
DESCRIPTION	4
MODEL DESCRIPTIONS (See Illustrations on Page 1)	4
STANDARD POWER SOURCE	4
Electric	4
Air	4
SUPPORT TOWER	5
WIZARD COVER LIFTER (Model F Only)	5
WIZARD DEKINKER	5
BUNG WRENCH	5
SECTION 2 - HOW TO USE YOUR WIZARD	6
BEFORE PLACING THE WIZARD ON A DRUM	6
PLACING THE WIZARD ON A DRUM	6
STARTING THE UNIT	6
CUTTING THE DRUM	7
Non-Automatic Units	7
Automatic Units	7
SECTION 3 - REMOVING DRUM LIDS	8
CUTTING TECHNIQUE (Models F and G Only)	8
SECTION 4 - CUTTER WHEEL POSITIONING	9
LOCATION OF CUTTING POSITION	9
HEIGHT OF CUT ADJUSTMENT	9
DEPTH OF CUT ADJUSTMENT	9
Non-Automatic Units	9
Automatic Units	9
SECTION 5 - PROPER USE AND CARE	10
SECTION 6 -- FACTORY SERVICING	10
SHIPPING INSTRUCTIONS	10
SECTION 7 -- GENERAL MAINTENANCE AND REPAIR	11
MAINTENANCE FOR INDUSTRIAL UNITS	11
FIELD SERVICING	11
RETAINING RINGS	11
SWIVEL CONNECTOR REMOVAL	11
DRIVE CHAIN REMOVAL	11
HEAD REMOVAL AND REPLACEMENT	12
LUBRICATION	12
Electric Motors	12
Gear Reducers	12
SECTION 8 -- CUTTER WHEEL AND DRIVE ROLLER ADJUSTMENT AND MAINTENANCE	12
CUTTER WHEEL OR DRIVE ROLLER REMOVAL AND REPLACEMENT FROM FRONT SHAFT	12
CUTTER WHEEL OR DRIVE ROLLER REMOVAL AND REPLACEMENT FROM REAR SHAFT	12
SECTION 9 -- SHAFT ASSEMBLIES	13
FRONT SHAFT REMOVAL AND REPLACEMENT	13
REAR SHAFT REMOVAL AND REPLACEMENT	13
SECTION 10 -- TROUBLESHOOTING PROCEDURES	15
ELECTRIC MODELS	15
Unit does not run (may also give off sparks)	15
Unit stalls or does not start	15
Unit does not cut drums	15
Unit is unstable – wobbles while traveling around drum	15

TABLE OF CONTENTS

Top drum head cannot be removed (Model F)	15
Unit does not run or cut	15
AIR MODELS	16
Unit does not run	16
Unit runs too slow	16
Unit does not cut drums (<i>Manual models</i>)	16
Unit does not cut drums (<i>Automatic models</i>)	16
Top drum head cannot be removed (Model F)	16
Unit does not run or cut	16
SECTION 11 – PARTS LISTS	17
ALL THREE UNITS	17
SECTION 12 -- GLOSSARY.....	21

Model Designation and Features

Standard Duty WIZARD Drum Openers come in three basic models (F, G and J). Each model opens a drum in one of three ways:

- 1) **(OC)** cutting around the outside diameter of the chime (the flat or round rim that fastens the lid to the drum).
- 2) **(IC)** cutting around the inside diameter of the chime.



Model FA



Model RGA



Model GS



Model JA

- 3) **(OS)** cutting around the drum shell below the chime.

All models operate on either air or electricity. Air driven models F, G and J are also available with an air driven regulator to automatically maintain cutter wheel force through an integral air cylinder. The following table shows the eleven currently available variations of the four standard duty basic model groups:

Model No.	Power Source		Auto.	Type	Color	Comments
	Air	Elec.	Air	Of Cut		
FS		X	NO	OC	White	USDA approved for Food industry applications.
FA	X		NO	OC	White	Same as FS. Recommended for washdown areas
RFA	X		YES	OC	White	Same as FS but with cutting pressure automatically maintained.
GS		X	NO	IC	Yellow	For general purpose use. Reuse or scrap drum.
GA	X		NO	IC	Yellow	Same as GS.
RGA	X		YES	IC	Yellow	Same as GS but with cutting pressure automatically maintained.
JS		X	NO	OS	Blue	Scrap drum.
JA	X		NO	OS	Blue	Same as JS.
RJA	X		YES	OS	Blue	Same as JS but with cutting pressure automatically maintained.

SERIAL NUMBERS: Always specify model and serial number (located on housing nameplate) in correspondence and parts requests. This identification is the key to many engineering details applying to your deheader.

 <i>Division of Hydro-Thermal Corporation Providing Solutions Worldwide</i>	DRUM DEHEADER Patents found at www.wizarddrumtool.com
MODEL NO. <input type="text"/>	400 PILOT COURT, WAUKESHA, WI 53188
SERIAL NO. <input type="text"/>	PHONE: (262)548-8910 FAX: (262)548-8915
DATE OF MFG. <input type="text"/>	TOLL FREE: (800) 828-8628
	PART NO. 8325

GENERAL WARNINGS AND PRECAUTIONS**ATTENTION**

This section must be read thoroughly before operating any equipment supplied by WIZARD Drum Tool Co. Failure to do so may result in damage to equipment and/or severe injury to personnel.

- When using the unit, make sure you are wearing all personal safety equipment such as gloves, safety glasses, and steel toe boots.

DANGER
ELECTRICAL
HAZARD

1. To avoid serious injury or death from electrical shock, make certain the unit is properly grounded.
2. Do not operate any of the electrical units in wet areas.
3. Always use the correct voltage supply as indicated on the unit motor nameplate.
4. Do not use power cord if damaged or frayed.

DANGER
MECHANICAL
HAZARD

1. Flip switch to "OFF" position.
2. In the event of a temporary power loss, there is the potential that the unit may be restarted automatically if the power switch is left in the "ON" position!
3. Keep all body parts away from the cutter wheel and roller whenever the power is on!
4. If the unit stalls due to blockage between the cutter wheel and the roller, always turn the unit off before attempting to dislodge any debris!
5. The chime of a cut drum may be sharp! Caution should be used when attempting to remove the lid from the drum. It is recommended that leather work gloves be worn when handling cut chimes.
6. Disconnect the power supply (electrical or air) before performing any maintenance on the unit!
7. Do not operate unit on flooring that is not level. The drum may tip over during operation.

The following applies to units purchased for use in non-explosive environments:

DANGER
EXPLOSIVE
HAZARD

1. Do not use any of the units to remove the lids off drums which may contain explosive materials.
2. **THE UNITS ARE NOT TO BE OPERATED IN EXPLOSIVE ENVIRONMENTS!**
3. Extreme care must be taken so that the unit is not operated in any manner to potentially ignite the drum contents and/or any explosive material.

SECTION 1 - GENERAL INFORMATION

DESCRIPTION

The WIZARD drum openers are portable, self-propelled and designed to cut the tops and/or bottoms of standard, 30-55 gallon (208 liters) steel drums up to 16 gauge.

All models are available with either an electric or air motor. Models F, G and J are available with an automatic air powered cutting feature.

WIZARD designs all its drum deheaders for long life, maximum reliability and simplified maintenance. Modular construction permits easy disassembly and adjustment, making parts accessible for repair or replacement with a spare.

MODEL DESCRIPTIONS (See Illustrations on Page 1)

Model F opener (white) includes USDA-compliant parts and an USDA-approved cutting method that cuts on the OUTSIDE of the drum chime. Designed specifically for food industry aseptic drums, no part of the Model F touches the drum contents. The outside cut also prevents dirt, paint chips or other debris from falling into the drum and contaminating its contents when opening the drum. The drum deheader's patented, continuous cutting operation and round cutter wheel leave a completely smooth edge, free of slivers or burrs. The drum lid remains secure to protect the drum contents until it is removed with a cover lifter.

The Model G opener (yellow) cuts on the INSIDE of the drum chime and leaves a smooth burr-free edge for safe handling. This versatile model is considered a general purpose opener because opened drums can either be used for utility containers or sold for scrap. This model has a small, 1-1/2" diameter cutter wheel that travels between the chime and bung fittings as it cuts. It is designed to open standard, 30-55 gallon industrial drums of up to 16-gauge steel with either flat or round chimes.

CAUTION

(For model J) Since the lid becomes completely separated from the drum when cut, the unit has the potential to fall off the drum. Use caution!

Model J opener (blue) cuts the drum shell BELOW the chime. This model was designed for drum disposal because it removes the entire drum head. Removing both top and bottom heads of a drum makes it easy to flatten or crush the drum, store it and later sell it for scrap.

STANDARD POWER SOURCE

WARNING

To avoid serious injury or death from electric shock, make sure the unit is properly grounded and do not use the electric model in wet areas.

Electric

Totally enclosed, fan cooled, permanently lubricated helical gear/needle bearing gear motor. Furnished standard with 1/3 HP, 110 volt single phase, 60 Hz, electric drive and swivel connectors matching standard single grounding plugs. Deheaders are also available in 220VAC 50/60Hz configurations. Satisfactory operation requires a 14ga or larger 3 prong plug properly grounded to earth ground.

Air

Variable speed, vane-type air motor and speed reducer. Develops approximately 1/2 HP at 40 psig (275 kPa) (with 25 cfm (0.71 m³/min) free air. Best performance is generally achieved with 80-100 PSIG air. Furnished with quick-disconnect coupling for 1/4 inch MINIMUM diameter air line. For long air hose runs we recommend larger 3/8 or 1/2 inch diameter hoses.

Also, for proper operation and maximum service life you MUST place pneumatic oil in the air line feeding into the motor.

SUPPORT TOWER

We recommend using a WIZARD Tower to suspend your WIZARD Drum Opener. The tower keeps the opener at working height and also prevents the opener from being dropped or from falling off a wobbly drum.



WIZARD COVER LIFTER (Model F Only)

After the WIZARD cuts the chime the lid is ready to be lifted vertically off the drum with a WIZARD Cover Lifter. The cover lifter will remove a properly cut lid quickly and easily. Drum lids may be reused to cover drum.

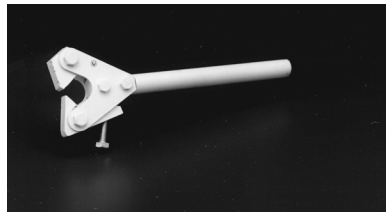

WIZARD DEKINKER

Easily straightens bent or dented chimes so your WIZARD Drum Openers can operate with maximum efficiency. Reseals leaking drums caused by bent chimes.

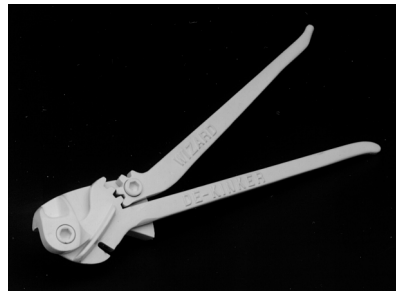

BUNG WRENCH

All-plug universal wrench easily, safely opens all known styles of American and foreign-made bungs and fittings. Ductile iron and non-ferrous style are available.

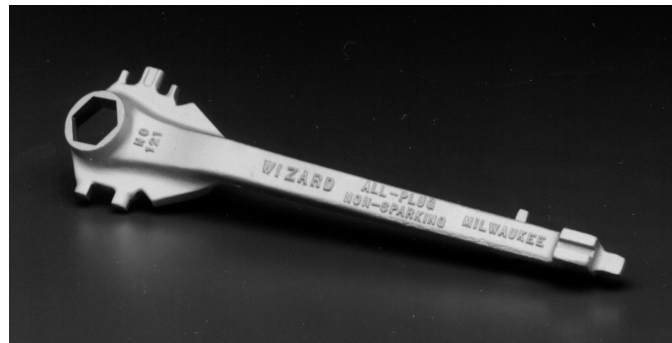

SECTION 2 - HOW TO USE YOUR WIZARD

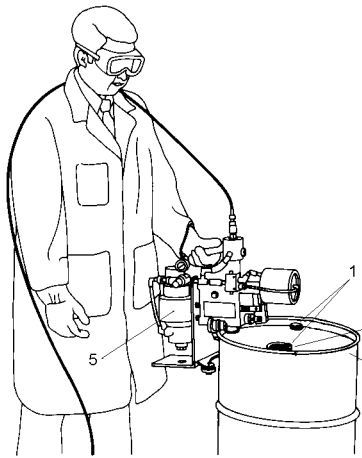

Figure 1

BEFORE PLACING THE WIZARD ON A DRUM

1. See Figure 1. Remove the plugs from the bung fittings with a WIZARD WRENCH (1 and 2).
2. Hammer down the bungs so they do not block or interfere with either the drive roller or cutter wheel. Note: For Model G with 1-1/2" diameter cutter wheel, only hammer bungs less than 1-1/2" from the drum chime.
3. Straighten any bent chime using a WIZARD Dekinker or hammer them into original contour (3).
4. Make sure the cutter wheel is in the retracted position, away from the drive roller to allow chime clearance.

Non-Automatic Units: Turn the adjusting screw handle about six turns counterclockwise.

Automatic Units: Turn on supply air to the drum opener and push/pull the plunger button of the air valve.

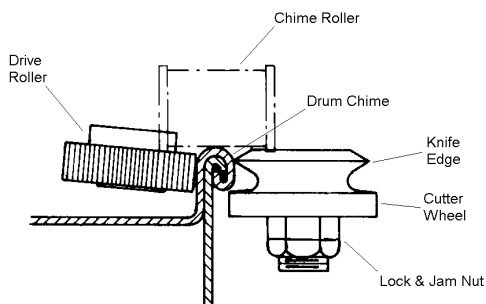
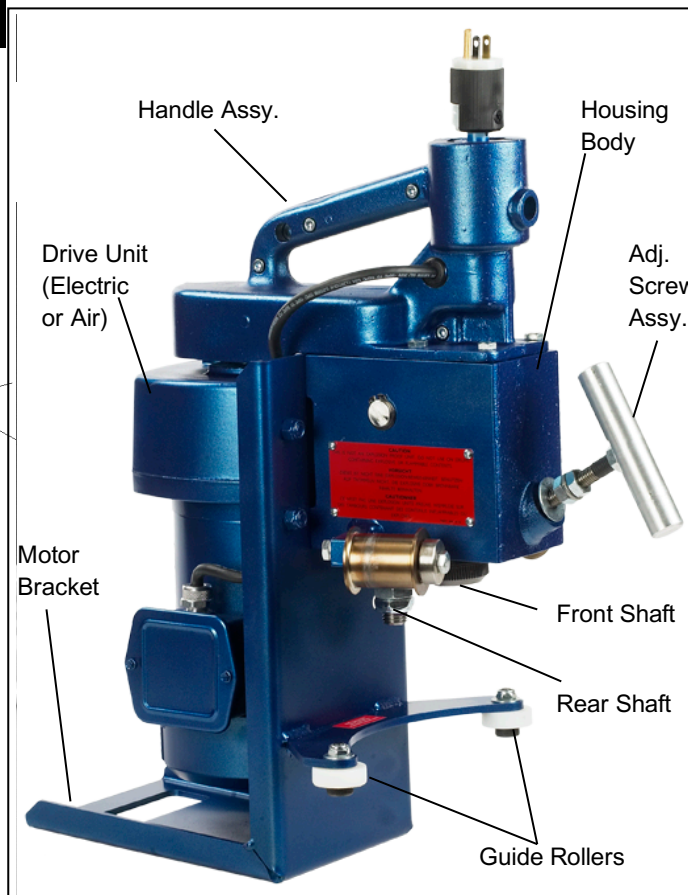

Figure 2



PLACING THE WIZARD ON A DRUM

1. See Figure 2. Place the WIZARD on the drum so the chime rollers ride on the top of the chime. If using an automatic air unit, push/pull the plunger button of the air valve to engage the cutter wheel and skip step 3 below.

CAUTION

Dropping the Wizard on the chime may damage the cutter wheel.

2. Check the unit for proper cutter height position. The cutter height position is factory set; however, you may need to make some minor adjustments. Please refer to section (4) before continuing.

3. Refer to Figure 1. Turn the adjusting screw handle (4) clockwise until the cutter wheel just touches the chime (3). The cutter wheel must not bite into metal at this point. Excess pressure prevents the electric or air motor (5) from reaching operating speed which may overload motor. The Warranty does not cover motor damage caused by overload.

STARTING THE UNIT

Many operators place the electric cord or air line over their left shoulder to keep it clear of the WIZARD. This also prevents the cord or line from wrapping itself around the drum as the opener rotates around the drum. Both the electric socket and the air line connector swivel 360° to prevent the line/cord from twisting during rotation.

Electric models have a toggle switch on the side of the handle. Air driven models have a ball valve located on the air line and an air regulator to adjust the rate of travel.

WARNING

DO NOT FOLLOW THE WIZARD AROUND THE DRUM.

Stand in one place and keep the cord or line out of the WIZARD's path. Let the WIZARD make one complete revolution and check for interference from bungs or chime.

CUTTING THE DRUM

Non-Automatic Units

1. Without stopping the drive unit, use **HAND ACTION ONLY** to turn the adjusting screw handle about 1/4 turn clockwise. **DO NOT USE** pipe, rod, or any other leveraging device to raise cutting force. Excessive cutting force may damage the housing body.
2. If you stop the unit for any reason, turn the adjusting screw handle 1/4 turn counterclockwise before you restart. This prevents overloading the drive unit.
3. After each revolution of the WIZARD around the drum, turn the adjusting screw handle another 1/4 turn clockwise. This gradually raises pressure on the cutter wheel so it can cut through the drum or outer chime layer of metal. As the metal splits, it makes a popping or cracking sound. Usually only 2 to 5 revolutions are enough to cut through the metal.
4. After you finish cutting the drum or its chime, turn the adjusting screw handle six turns counterclockwise to retract the cutter wheel. Tilt the WIZARD toward the center of the drum lid and lift the WIZARD off the drum.

Automatic Units

1. Apply air to the opener and push/pull the plunger button of the air valve. With the cutter wheel engaged, the cutting action is automatic as the WIZARD travels around the drum. As the metal splits, it makes a popping or cracking sound. Usually only 2 to 5 revolutions are enough to cut through the metal.
2. After you finish cutting the drum or its chime, push/pull the plunger button of the air valve to disengage the cutter wheel. Tilt the WIZARD toward the center of the drum lid and lift the WIZARD off the drum.

SECTION 3 - REMOVING DRUM LIDS

Model F - The WIZARD Cover Lifter will remove a properly cut lid quickly and easily.

Model G - A soft hit with a long-handled mallet on the top of the drum lid will usually dislodge it and, depending on where it is hit, will either fall to the bottom of the drum or tip sideways so it can easily be removed. Drum lids are sharp so care should be taken.

Model J - After the drum shell is cut the top is free to be lifted off the drum.

CUTTING TECHNIQUE (Models F and G Only)

The correct way to open a drum is to cut cleanly through only the single outer metal layer of the chime. If the cut is too shallow, it is difficult to remove the head. If the cut is too deep, the cutter wheel life is shortened. With some practice, judging optimum cutting depth is easily done.

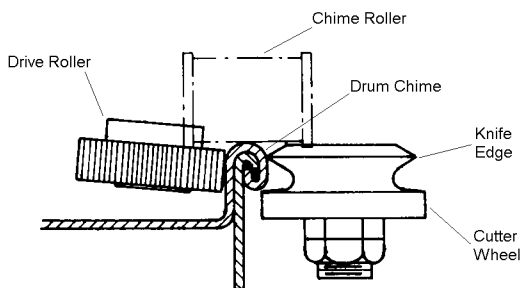

Figure 3A Model F

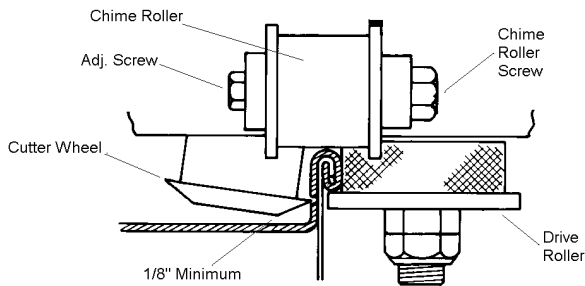

Figure 3B Model G

SECTION 4 - CUTTER WHEEL POSITIONING

Accurate positioning of the cutter wheel on the drum chime is critical to getting the best performance from your WIZARD Drum Opener. Read Section 4 carefully and check periodically for proper cutter wheel positioning.

LOCATION OF CUTTING POSITION

Model F - Figure 3A. The cutter wheel shoulder must contact the bottom edge of chime when the cutter knife edge just meets the chime. However, the shoulder must actually touch the chime. The knife edge of the cutter wheel should be from 1/8" to 5/32" (3.1 to 3.9 mm) below the top of the chime.

Model G - Figure 3B. The drive roller flange should just clear the underside of the chime. The cutter wheel should be approximately 1/8" (3.1 mm) or more above the drum lid.

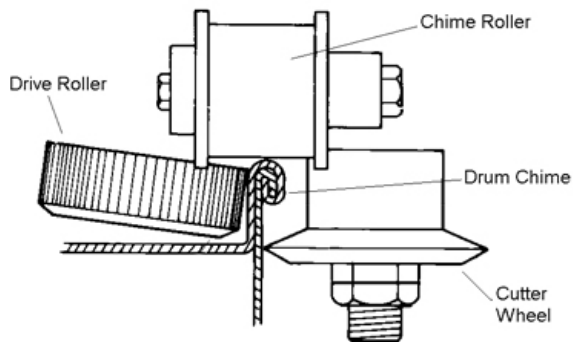

Figure 3C Model J

Model J - Figure 3C. The cutter knife edge should contact the drum only far enough under the chime to clear it.

HEIGHT OF CUT ADJUSTMENT

The chime roller settings control the height of the cut. Because of the variety of drums, you must sometimes change this factory set adjustment. The procedure is the same for all models. Refer to Figures 3A through 3C above, and set the height of the cut as follows:

1. Place the drum opener on the chime as described in Section 2.
2. Using two 9/16" open or box end wrenches, loosen the chime roller screw while holding the adjustment screw (Figure 4).
3. The chime roller axle (shaft) is eccentric to the outside diameter (Figure 4). Turn the adjustment screw while holding the chime roller screw to raise or lower the cutting position.
4. Hold the adjustment screw and tighten the chime roller screw.

5. Repeat steps 2 through 4 on the second chime roller to level the opener on the drum.

NOTE

To be sure that the drum opener is sitting level on the drum, check that the bottom edge of the housing body is parallel with the top edge of the drum chime.

6. Engage the cutter wheel either by turning the manual adjusting screw handle (non-automatic units) or by applying air to the drum opener and pressing the top button on the air valve (automatic units). Observe the cutter wheel position and compare it to the appropriate figures.

7. Retract the cutter wheel and repeat the procedure until the cutter wheel position is correct.

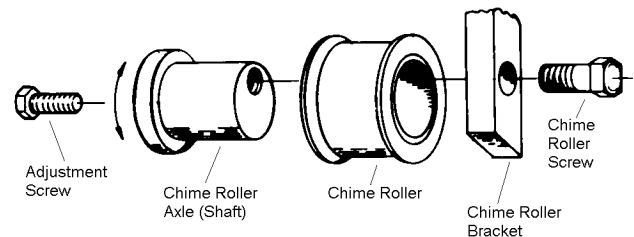

Figure 4

NOTE

All of the Part numbers in the following sections refer to the three exploded views and parts lists in Section 11.

DEPTH OF CUT ADJUSTMENT

Since the cutter wheel wears during normal use, you must occasionally change the factory setting for depth of cut.

Non-Automatic Units

1. Loosen the nuts on the adjusting screw handle and back them away from the housing body.
2. Make an experimental cut to determine the cutting depth needed to penetrate ONE layer and stop the machine at this setting.
3. Turn the nuts back against the housing body and tighten them together.

Automatic Units

1. Remove the lower linkage guard.
2. Loosen the set screw in the pressure rod boss on the front of the housing body.

3. Turn the pressure rod guide (3111) into the housing body.
4. Make an experimental cut to determine the cutting depth needed to penetrate ONE layer and stop the machine at this setting.
5. Turn the pressure rod guide out of the housing body until it contacts the flat of the pressure rod (3112).
6. Tighten the set screw.
7. Replace the lower linkage guard before operating the unit.

SECTION 5 - PROPER USE AND CARE

With proper use and care your WIZARD Drum Opener will give you long and dependable service.

1. Lubricate the unit properly. Refer to Section 7.
2. Do not drop your drum opener. If unit falls and damage is excessive or unit fails to operate, call for factory assistance.
3. Be certain your electrical connections and air line hookups leading to the drum opener are correct and safe.
4. DO NOT use any kind of levering tool on the manual adjusting screw handle. Excessive force may damage your drum opener.
5. Occasionally wire-brush the drive roller serration's.
6. All of the components of the front and rear shaft are drawn together using a self-locking nut which contains a nylon threaded insert. When properly tightened, all axial play should be removed from each shaft and some drag should be felt in the bearing when rotating the shaft. Check periodically that the front and rear shafts are tight and refer to Section 9 for proper shaft maintenance if they are not. If the shaft tightness requires repeated attention, the self-locking nut is worn and should be replaced.

SECTION 6 -- FACTORY SERVICING

Send units requiring major service to the factory. WIZARD will make a repair estimate and perform the repair only after your authorization is given.

NOTE: Please Contact Factory for Return Authorization before Returning Unit.

SHIPPING INSTRUCTIONS

When returning openers to the factory:

1. Get return authorization number from factory.
2. Clean all exterior and accessible parts.
3. Fasten an identification tag to your machine. The tag should show your company name and shipping address, and the model and serial number of your unit.

Ship PREPAID to:

**WIZARD Drum Tool Company
400 Pilot Court
Waukesha, WI 53188**

COD shipments are not accepted.

SECTION 7 -- GENERAL MAINTENANCE AND REPAIR

WIZARD designs all its drum openers for long life, maximum reliability and simplified maintenance. Modular construction permits easy disassembly and adjustment, making parts easily accessible for repair or replacement with a spare.

MAINTENANCE FOR INDUSTRIAL UNITS

Daily checks should be:

- Make sure all nuts and bolts are securely fastened
- Check cutter wheels for any chips and/or wear
- Check drive roller for wear
- Check proper alignment of chime rollers
- Make sure there is no binding of any gears or bearings
- Make sure drive roller is free of debris

Bi-monthly checks:

- Take nameplate off to make sure there is enough grease on gears
- Check air lines for cracking and pinching
- Check electrical lines for cracking and pinching
- Check T-handle for wear or thread damage

WARNING

Always use personnel safety equipment (PSE) when using this machinery.

The grease we prefer is food grade grease. It is safer for the environment.

FIELD SERVICING

Light servicing and maintenance is possible with ordinary hand tools. Replacement parts are available from factory stock. Use and experience will determine which parts to keep on hand for routine maintenance, such as cutter wheels or shaft assemblies. Call a certified Wizard technician for all questions.

Study the exploded view drawings in Section 11 and note relative positions of the parts before disassembly.

NOTE

Disconnect any electrical or air pressure supply from the drum opener before attempting to conduct any maintenance or repair

RETAINING RINGS

The pivot pin (3070) and one end of the rear shafts (3510 and 3512) have snap rings. You can easily remove these with snap ring pliers.

SWIVEL CONNECTOR REMOVAL

To remove the swivel from your WIZARD Opener, follow these simple steps:

1. Unplug the opener from the power outlet.
2. Remove the four 1/8" socket head cap screws (2144) holding the two handle halves together.

NOTE

It is not necessary to remove the entire handle.

3. Remove the two hex head cap screws (2106) holding the handle to the housing body from the handle half that is opposite from the power cord. Second half of handle remains attached to housing body. (DO NOT DISTURB THE DRIVE CHAIN.)
4. Disconnect motor leads from power switch and from one swivel connector lead.
5. Disconnect remaining swivel connector lead from power switch and remove swivel connector.
6. To install new swivel, refer to wiring instructions included with replacement swivel.

DRIVE CHAIN REMOVAL

Remove the drive chain (3190) by following these simple steps:

1. Remove the handle by removing the four hex head cap screws (2106) holding it to the housing body.
2. Open the chain at the connecting link, being careful not to lose the spring clip, and install new chain.

Or as an alternative:

1. Remove lower two nuts and cap screws from motor bracket and loosen or back off the top two nuts and cap screws about halfway to allow motor to tilt to a 30-45 degree angle. With motor tilted, chain becomes slack and can easily be removed from sprockets.
2. Install new replacement chain on smaller motor sprocket first and then on larger driven sprocket.

NOTE

If chain is too loose, remove slack by inserting flat washers or shims between the motor feet and bracket.

HEAD REMOVAL AND REPLACEMENT

For convenience and easy handling during maintenance operations, you may want to separate the head assembly from the drive unit and handle assembly.

1. Remove the handle assembly by removing the four hex head cap screws holding it to the housing body.
2. Remove the four cap screws holding the motor to the motor bracket.
3. Remove the four cap screws holding the motor bracket to the housing body.
4. Disengage the larger sprocket (3180) from the chain.

NOTE

During head assembly, make sure to put the chain back on the sprocket before installing the motor bracket. Install the lower screws first when attaching the bracket.

LUBRICATION

Periodically lubricate your WIZARD as follows:

1. Remove one side plate from the housing body.
2. Apply a generous amount of light grease to the shaft gears. Use Loctite Food Grade Grease NLGI #2, or equivalent, on all Model G and J openers. Use a food grade grease or equivalent on all Model F openers.
3. Grease pack bearings any time shaft is disassembled. Repack at any time if grease becomes dry or caked.

Electric Motors

The gear motor gets a lifetime lubrication at the factory with permanent, heavy fluid gear oil, so it should not be necessary to lubricate the gear motor.

Gear Reducers

Check the gearbox grease annually. If unit requires additional grease, use EP-O or equivalent. For proper operation and maximum service life, you MUST oil your inlet air line ports

SECTION 8 -- CUTTER WHEEL AND DRIVE ROLLER ADJUSTMENT AND MAINTENANCE

All machine tool cutting edges become dull through regular use. Although the WIZARD cutter wheel is made from high-grade hardened tool steel, it will eventually lose its edge after a lot of cutting. If the WIZARD needs more than 7 or 8

revolutions to dehead a drum, the cutter wheel may be dull. If the cutter wheel or drive roller becomes badly worn or chipped replace them as follows:

CUTTER WHEEL OR DRIVE ROLLER REMOVAL AND REPLACEMENT FROM FRONT SHAFT

1. Make sure cutter wheel or drive roller is in the retracted position. Remove T-handle.
2. Loosen set screws on gears. They have to be lowered to remove assembly.
3. Remove one snap ring holding the pivot pin (3070) in place. Remove the pin from the housing body.
3. Drop the front shaft carrier assembly downward and remove it from the housing body.
4. Remove the cotter pin and then the slotted hex nut from the front shaft.
5. Remove the set screw from the gear.
6. Remove the woodruff key from the shaft and disassemble the carrier assembly. The drive roller or cutter wheel may be difficult to remove because of the tight fit.
7. Install the new drive roller or cutter wheel on the top end of the shaft. Reassemble the carrier assembly, doing each step in reverse order of disassembly.
8. Install the front shaft carrier assembly in the housing body. Insert the pivot pin and attach the snap ring.

CUTTER WHEEL OR DRIVE ROLLER REMOVAL AND REPLACEMENT FROM REAR SHAFT.

1. Remove one side plate from the housing to expose the shaft gears (3100). Block the gears to prevent the shaft (3510 or 3512) from turning.
2. Remove the lock & jam nuts holding the cutter wheel or drive roller in place. Remove the cutter wheel or drive roller from the shaft.
3. Inspect woodruff key and replace if worn.
4. Install the new cutter wheel or drive roller on the shaft and secure it with the lock & jam nuts. Tighten until all vertical play disappears and there is a slight drag on the bearings.
5. Free the gears and install the side plate.
6. Make sure gears align and tighten set screws.

SECTION 9 -- SHAFT ASSEMBLIES

FRONT SHAFT REMOVAL AND REPLACEMENT

1. Remove the front shaft carrier assembly and its drive roller or cutter wheel as described in Section 8.
2. Remove slotted hex nut & cotter pin and loosen the set screw holding the shaft gear (3100). Remove the shaft (3499) from the assembly, drawing the shaft downward and through the gear.

NOTE

The bearing cups (outer races) are press-fitted and almost never need replacing.

3. Replace any worn parts and assemble the shaft as follows:

NOTE

If you remove the bearing cups and there is no press equipment for installation, use a soft hammer to tap the cups into position. When resetting the cups, insert a support in the gear cavity to prevent its deformation under pressure. (See Figure 5.)

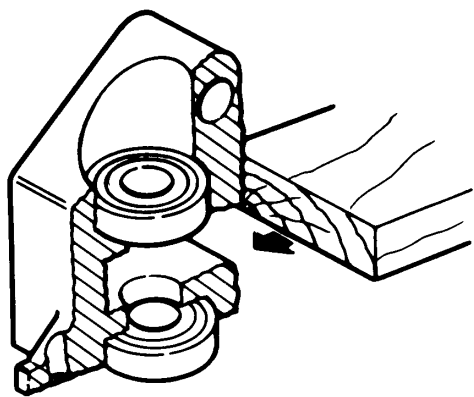

Figure 5

4. Install the drive roller or cutter wheel with its woodruff key (3130) on the bottom of the shaft.
5. Slide the shaft through the lower bearing (3090), gear (3100) and upper bearing (3090). Be sure the gear's woodruff key is in place, but do not tighten the gear setscrew at this point.
6. Install the top slotted hex nut & cotter pin. Tighten until all end play disappears and there is a slight drag on the bearings.
7. Install the front carrier assembly in the housing body. Install the pivot pin (3070) and its snap rings (3120).

8. Align the shaft gears (3100) and tighten the set screw.

REAR SHAFT REMOVAL AND REPLACEMENT

1. Remove the four hex head cap screws (2106) holding the handle to the housing body. Remove the handle, but do not disconnect the motor leads or air line.
2. Remove one side plate from the housing body and block the shaft gears (3100).
3. Unscrew the lock & jam nuts from the lower end of the rear shaft. Remove the cutter wheel or drive roller and its key from the shaft.

NOTE

The cone of the lower bearing is now free to drop out.

4. Remove the lower bearing cone (3090A).

NOTE

The bearing cups (outer races) are press-fitted and almost never need replacing.

5. Remove the snap ring (3120) from the upper end of the shaft and remove the sprocket (3180) and its key (3130) from the rear shaft (3510).
6. Remove the spacer (3110) from the shaft on Models FS, FA and RFA and loosen the set screw on the shaft gear (3100).
7. Draw the shaft downward through the upper bearing and shaft gear, out of the housing body.

NOTE

The top bearing cone and shaft gear are now free for removal.

8. Replace worn or broken parts. If the bearing cups need replacement, see NOTE and Figure 5 at left. Assemble the rear shaft as follows:
9. Install the snap ring (3120) on the rear shaft.
10. Insert the top woodruff key (3130) in the shaft and install the sprocket gear (3180) on it. Gently tap the sprocket into position using a soft mallet.
11. Install the spacer (3110) on the shaft.
12. Install the bearing (3090) on the shaft.
13. Install the second woodruff key (3130) on the shaft.
14. Position the shaft gear (3100) in the gear cavity.

15. Insert the shaft through the top bearing cup into the gear housing, through the shaft gear (3100), and through the bottom bearing cup. Install the shaft gear over its key (3130), tapping lightly with a soft mallet to seat it.

16. Install the lower bearing (3090).

17. Install the cutter wheel or drive roller and the last woodruff key (3130) on the shaft.

18. Install and tighten the bottom lock & jam nuts. Tighten until all end play disappears and there is a slight drag on the bearings.

19. Align the shaft gears (3100) and tighten the set screws.

SECTION 10 -- TROUBLESHOOTING PROCEDURES

ELECTRIC MODELS

Problem	Possible Cause	Remedy (see note below)
Unit does not run (may also give off sparks)	Faulty power connection.	Check replace line cord.
	Swivel connector broken.	Replace swivel connector.
	Power switch broken.	Replace toggle switch.
	Loose electrical connection.	Check wiring inside handle.
Unit stalls or does not start	Excessive pressure on cutter wheel (manual units only).	Back off adjusting screw handle (manual models only).
Unit does not cut drums	Cutter wheel dull or chipped.	Reset position of locknuts on adjusting screw handle to obtain more cutting depth. Replace cutter wheel
	Cutter wheel does not penetrate deep enough to get through layer of metal.	Reset position of locknuts on adjusting screw handle to obtain more cutting depth.
	Not enough cutting passes around drum.	Increase the number of cutting passes.
	Adjusting screw handle bottoms out (manual units only).	Adjust locknuts for greater travel on adjusting handle (manual units only).
	Not enough pressure (force) on cutter wheel.	Tighten adjusting screw handle.
Unit is unstable – wobbles while traveling around drum	Chime rollers out of alignment.	Adjust chime rollers until unit is level.
	Drum chime kinked.	Straighten chime using WIZARD Dekinker.
	Drum shell dented.	Guide unit past dented area.
Top drum head cannot be removed (Model F)	Outer metal chime layer not cut completely through.	Tighten cutter wheel adjusting screw (manual units only). Increase the number of cutting passes.
	Cut location too low.	Cut above center of chime.
	Cutter wheel not penetrating metal.	Replace dull or chipped cutter wheel.
	Improper pry tool used to remove lid.	Use WIZARD cover lifter.
Unit does not run or cut	Defective motor.	Replace motor.
	Gears in body housing not meshing.	Adjusting screw out too far – adjust.
	Woodruff key sheared or missing.	Check all shaft parts for Woodruff keys.
	Cutter wheel/drive roller hits bung.	Hammer down bungs for clearance.
	Drive roller worn or dirty.	Replace or clean drive roller serrations with a wire brush.

NOTE: Please Contact Factory or Hydro-Thermal Technician for Return Authorization before Returning Unit.

Troubleshooting (cont.)

AIR MODELS

Problem	Possible Cause	Remedy (see note below)
Unit does not run	Insufficient air pressure.	Check air supply, compressor and/or regulator.
	Clogged air lines.	Check air connections.
	Air motor frozen or jammed.	Reverse air line to free vanes. Check air line lubricator for oil.
	Faulty throttle/sleeve valve	Replace valve.
Unit runs too slow	Air pressure too low	Increase air pressure.
	Excessive pressure on cutter wheel (manual models only).	Back off adjusting screw handle (manual models only).
Unit does not cut drums (Manual models)	Cutter wheel dull or chipped.	Replace cutter wheel.
	Cutter wheel does not penetrate deep enough to get through layer of metal.	Reset position of locknuts on adjusting screw handle to obtain more cutting depth.
	Not enough cutting passes around the drum.	Increase the number of cutting passes.
	Adjusting screw handle bottoms out.	Adjust locknuts for greater travel on adjusting handle.
	Insufficient pressure (force) on cutter wheel.	Tighten adjusting screw handle.
Unit does not cut drums (Automatic models)	Not enough cutting passes around the drum.	Increase the number of cutting passes.
	Air pressure too low	Increase air pressure.
	Insufficient pressure rod travel to obtain necessary cutter wheel force.	Reset pressure rod guide screw for greater pressure rod travel.
	Loss of air pressure in cylinder.	Replace seals and O-rings in cylinder.
Unit is unstable – wobbles while traveling around drum	Chime rollers out of alignment.	Adjust chime rollers until unit is level.
	Drum chime kinked.	Straighten chime using WIZARD Dekinker.
	Unit running too fast.	Reduce air motor pressure.
	Drum shell dented.	Guide unit past dented area.
Top drum head cannot be removed (Model F)	Outer metal chime layer not cut completely through.	Tighten cutter wheel adjusting screw (manual units only). Increase the number of cutting passes.
	Cut location too low.	Cut above center of chime.
	Cutter wheel not penetrating metal.	Replace dull or chipped cutter wheel.
	Improper pry tool used to remove lid.	Use WIZARD cover lifter.
Unit does not run or cut	Defective air motor.	Replace air motor.
	Gears in body housing not meshing.	Adjusting screw out too far – adjust.
	Woodruf key sheared or missing.	Check all shaft parts for Woodruf keys.
	Cutter wheel/drive roller hits bung.	Hammer down bungs for clearance.
	Drive roller worn or dirty.	Replace or clean drive roller serrations with a wire brush.

NOTE: Contact Factory for Repair Authorization before Returning Unit.

SECTION 11 – PARTS LISTS**ALL THREE UNITS**

PART NO.	DESCRIPTION	QTY
1117-5	STUD THREADED	1
1358	ROUND 2.00" DIA.	1
1386	ROUND 1.00" DIA.	5
1780	ROUND 2.00" DIA.	3
1786	ROUND 2.00" DIA.	3
11340	ORING #2-016 EPDM	1
1807	ROUND 2.25" DIA	1
1840	ROUND .749" , G&P	10
1876	ROUND .75" DIA.	0
2144	SCREW CAP SOC	4
2222	SCREW SELF TAP	1
3043	COVER	1
3046	SHAFT	1
3047	SHELL, SWIVEL, 3	1
3053	INSERT THREADED	8
3054	INSERT THREADED	1
3058	BRACKET ROLLER	2
3062	INSERT 0.625" OD X	1
3090B	BEARING CUP	2
3091	BEARING BALL	1
3201	HANDLE FOR	1
3203	ROD THREADED	1
3270	TERMINAL ELEC	1
3291	PLUG ELECTRICAL,	1
3293	NUT WIRE 73B	2
3835	RING NEUTRAL,	1
3838	RING HOT,	1
3840	RING GROUND,	1
5313	NUT HEX JAM	3
5608	WASHER LOCK	1
6604	WIRE WHITE (FOR	1
6605	WIRE BLACK (FOR	1
6606	WIRE GREEN (FOR	1
6620	BRUSH WIRE	1
6621	BRUSH WIRE HOT	1
6622	BRUSH WIRE	1
6630	TUBING .50" DIA.	1
C0011	CASTING BODY	1
C0014	CASTING CARRIER	1
C0016	CASTING HANDLE,	1
11684	VALVE, BALL, 0.25"	1
11685	AIR PRESSURE	1
11686	GUARD LINKAGE	1
11687	GUARD LINKAGE	1
12111	RETAINING RING	1
2104	SCREW CAP HX HD	3
2106	SCREW CAP HX HD	8

Parts Lists (cont.)

PART NO.	DESCRIPTION	QTY
2112	SCREW CAP HX HD	2
2142	SCREW MACH HEX	4
2148	SCREW CAP SOC	4
2159	SCREW CAP SOC	2
2166	SCREW SHOULDER	3
2211	SCREW SELF TAP	8
27068	ADAPTER PLUG,	1
3011	MOTOR AIR 1/2 HP	1
3023E	HANDLE ASSY,	1
3030	SWITCH MOTOR -	1
3038	NAMEPLATE (FOR	1
3042	CONNECTOR,	1
3056	BODY HOUSING,	1
3059	BODY HOUSING,	1
3060	CARRIER ASSY FOR	1
3063	CARRIER ASSY FOR	1
3070	PIN PIVOT (SS)	1
3090A	BEARING CONE,	4
3097	BUSHING OILITE	1
3099	LEVER, 410 SS,	1
3100	GEAR DRUM	2
3110	SPACER SHAFT	1
3111	GUIDE ROD	1
3112	ROD PRESSURE	1
3114	SUPPORT BRACKET	1
3115	PISTON ROD	1
3117	SUPPORT	2
3118	PISTON, CYLINDER	1
3119	BRACKET, AIRLINE	1
3120	RETAINING RING	3
3120	RETAINING RING	4
3124	COVER, CYLINDER	1
3126	RETAINING RING	1
3129	HANDLE T-BAR	1
3130	KEY WOODRUFF	5
3133	CYLINDER AIR,	1
3140	SPRING, 0.625" Lg	2
3171	SPROCKET DRIVEN	1
3180	SPROCKET DRIVEN	1
3190	CHAIN DRIVE 31	1
3198	ROLLER GUIDE	2
3200	ROLLER GUIDE -	2
3204	BLOCK AIRLINE,	1
3250	LINK OFFSET #41-	1
3280	TERMINAL ELEC	1
3284	REDUCER GEAR	1
3293	NUT WIRE 73B	3
3310	GROMMET,	1
33305	WASHER LOCK #10,	4

Parts Lists (cont.)

PART NO.	DESCRIPTION	QTY
3340	CONNECTING	1
3452	WIRE SJEW-16/3,	2
3499	SHAFT FRONT, FOR	1
3510	SHAFT	1
3517	CUTTER WHEEL	1
3520	CUTTER WHEEL	1
3532	CUTTER WHEEL,	1
3546-1	CHIME ROLLER,	2
3548	CAM PIN, 2.50"	2
3551	DRIVE ROLLER	1
3552	DRIVE ROLLER,	1
3572	BUSHING OILITE	4
3576	BRACKET MOTOR	1
3659	CONNECTORS	1
3659A	NUT LOCK	1
3761	ADAPTER FLANGE,	1
3803	NIPPLE .25" NPT X	2
3807	NIPPLE CLOSE .25"	4
3812	TEE .25" NPT	1
3815	ELBOW 0.25" 90	1
3864	GASKET ROUND 4	1
5237	LOCKNUT HEX	4
5238	LOCKNUT HEX	2
5346	LOCKNUT HEX,	3
5371	LOCKNUT JAM,	1
5372	NUT HEX JAM	1
5374	NUT HEX SLOTTED	1
5601	WASHER FLAT 5/16"	2
5602	WASHER FLAT 3/8"	1
5606	WASHER LOCK	2
5612	WASHER LOCK	4
6087	ORING #2-239 70	1
6088	ORING #2-341 70	1
6089	ORING #2-112 70	1
6301	SEAL .50" ID X .875"	2
7036	AIR REGULATOR	1
7037	SWITCH AIR 4 WAY	1
8064	PIN COTTER	1
8080	NAMEPLATE	1
8125	NAMEPLATE,	1
8502	CONNECTOR MALE	2
8504	ELBOW MALE 8 X 4	1
8514	CONNECTOR MALE	1
8523	HOSE NATURAL	10
8524	HOSE NATURAL,	16
8527	ELBOW MALE	1
8533	MUFFLER AIR 1/4	2

SECTION 12 -- GLOSSARY

The following terms are used often in describing the use of the WIZARD in deheading steel drums. A proper understanding of these terms will help you use your deheader.

BUNG -- Fittings located on drum lid. On chemical or oil drums, two bungs, usually 3/4" and 2" (19 and 51 mm) diameter are located near edge of the drum. Bungs will interfere with the drive roller or the cutter wheel unless they are hammered down.

CHIME -- The rolled edge of the top and bottom of the drum. Most industrial drums have a flat seam (double seam) comprised of 5 layers of metal. Aseptic food drums have a round seam (triple seam) comprised of 7 layers of metal.

CUTTING DEPTH -- How deep the cutter wheel penetrates the drum metal. Proper cutting technique requires that cutting depth be set to cut through only one layer of metal.

DRIVING UNIT -- The electric or air motor that powers the propelling action of the opener. Drive unit is considered to be at the rear of the opener. (See illustration below.)

SHAFT, REAR -- Shaft closest to the drive unit is defined as the rear shaft. (See illustration below.)

SHAFT, FRONT -- Shaft farthest from the drive unit is defined as the front shaft. (See illustration below.)

HEAD ASSEMBLY -- The housing body that contains the heart of the WIZARD. This assembly contains gearing, bearings, drive roller, cutter wheel, shafts, adjusting screw and other parts intrinsic to the cutting action of the deheader.

HOUSING BODY -- Hollow rectangular casting that encases the rear shaft and the front shaft carrier assembly. (See illustration below.)

DRUM SHELL -- The steel body of the drum usually made from 18 or 20 gauge steel.

U.S.D.A. -- United States Department of Agriculture. The WIZARD Model F has been approved for use in meat and poultry plants operating under Federal inspection.

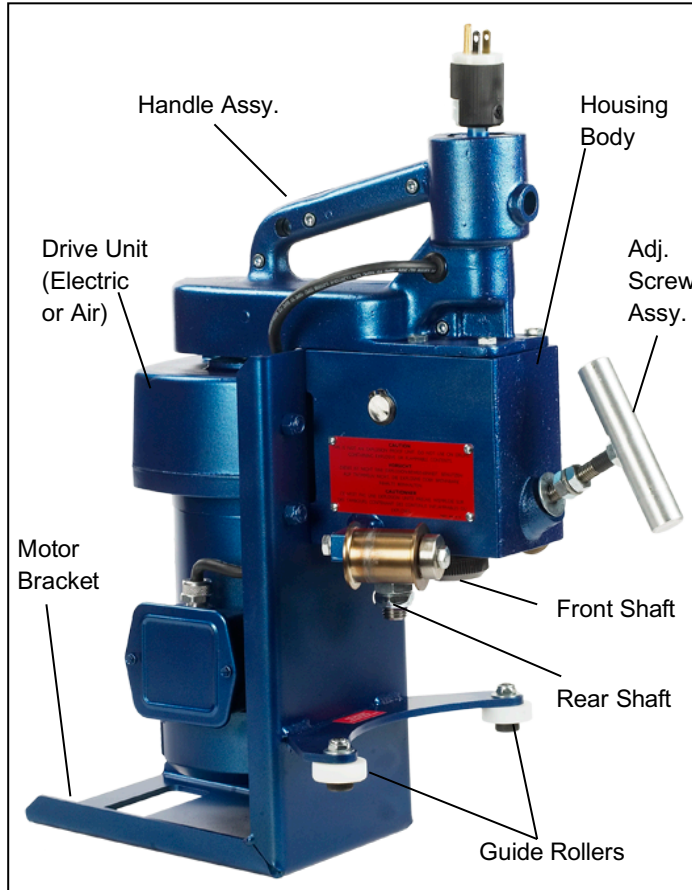

Limited Warranty

Wizard® Drum Tool Company guarantees the materials, components, and workmanship in its drum tool products to be of the highest quality and to be free of defects in material and workmanship for a period of 1 year from the delivery date. Any defective component or parts will be exchanged at our factory with replacement parts, shipped to you prepaid, if found to be defective from other than overload, abuse, careless or negligent use, or failure to maintain the unit as recommended by company operating and service manuals. Typical use would be 20-30 drums per week. A major rebuild is expected every 2500 drums. The company's liability does not extend to damage or malfunction resulting from alterations from original design of the equipment or failure to follow normal operating procedures.

There are no warranties, either express or implied, of fitness for a particular purpose which shall extend beyond the warranty period of 1 year from the date of delivery. No responsibility is assumed from any incidental or consequential damages except for those allowed under state law.

The company reserves the right under its product improvement policy to change construction or design details and furnish equipment when so modified without reference to illustrations or specifications.